

Features

- n Wide 8V to 32V Input Voltage Range
- n Output Adjustable from 0.8V to 26V
- n Minimum Drop Out 0.3V
- n Fixed 160KHz Switching Frequency
- n Maximum 2A Output Current Capability
- n Internal Optimize Power MOSFET
- n Excellent line and load regulation
- n High efficiency up to 92%
- n TTL shutdown capability
- n EN pin with hysteresis function
- n With output constant current loop
- n Built in Constant Voltage (CV) Loop
- n Built in Constant Current (CC) Loop
- n Built in thermal shutdown function
- n Built in output short protection
- n SOP8 package

General Description

The XL2005 is a 160 KHz fixed frequency PWM buck (step-down) DC/DC converter, capable of driving a 2A load with high efficiency, low ripple and excellent line and load regulation. Requiring a minimum number of external components, the regulator is simple to use and include internal frequency compensation and a fixed-frequency oscillator.

The PWM control circuit is able to adjust the duty ratio linearly from 0 to 100%. An enable function, an over current protection function is built inside. An internal compensation block is built in to minimize external component count.

Applications

- n Car Charger
- n Battery Charger



Figure1. Package Type of XL2005

Pin Configurations

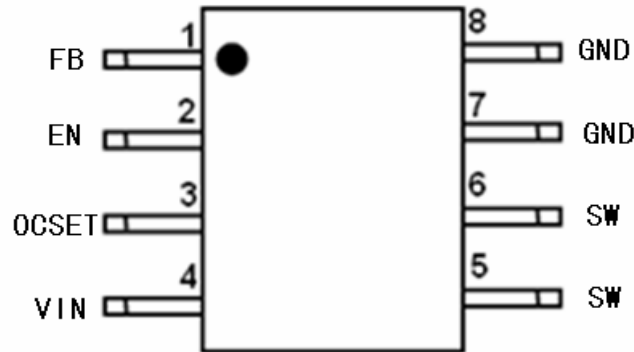

Figure2. Pin Configuration of XL2005 (Top View)

Table 1 Pin Description

Pin Number	Pin Name	Description
1	FB	Feedback Pin (FB). Through an external resistor divider network, Feedback senses the output voltage and regulates it. The feedback threshold voltage is 0.8V.
2	EN	Enable Pin. Drive EN pin low to turn off the device, drive it high to turn it on.
3	OCSET	Output Constant Current Set Pin.
4	VIN	Supply Voltage Input Pin. XL2005 operates from a 8V to 32V DC voltage. Bypass Vin to GND with a suitably large capacitor to eliminate noise on the input.
5,6	SW	Power Switch Output Pin (SW). Output is the switch node that supplies power to the output.
7,8	GND	Ground Pin.

2A 160KHz 32V Buck DC/DC Converter With CV/CC Loop

XL2005

Function Block

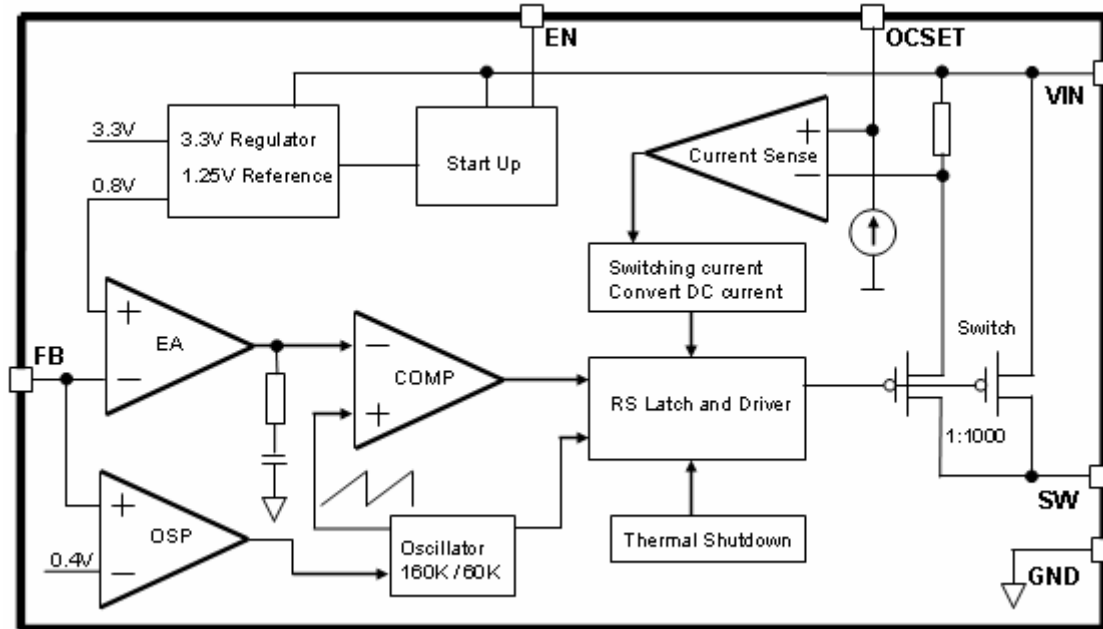

Figure3. Function Block Diagram of XL2005

Ordering Information

Package	Temperature Range	Part Number	Marking ID	Packing Type
		Lead Free	Lead Free	
		XL2005E1	XL2005E1	Tube
		XL2005TRE1	XL2005E1	Tape & Reel

XLSEMI Pb-free products, as designated with “E1” suffix in the par number, are RoHS compliant.

Absolute Maximum Ratings (Note1)

Parameter	Symbol	Value	Unit
Input Voltage	V _{in}	-0.3 to 34	V
FB Pin Voltage	V _{FB}	-0.3 to V _{in}	V
EN Pin Voltage	V _{EN}	-0.3 to V _{in}	V
SW Pin Voltage	V _{SW}	-0.3 to V _{in}	V
Power Dissipation	P _D	Internally limited	mW
Thermal Resistance (Junction to Ambient, No Heatsink, Free Air)	R _{JA}	100	°C/W
Operating Junction Temperature	T _J	-40 to 125	°C
Storage Temperature	T _{STG}	-65 to 150	°C
Lead Temperature (Soldering, 10 sec)	T _{LEAD}	260	°C
ESD (HBM)		> 2000	V

2A 160KHz 32V Buck DC/DC Converter With CV/CC Loop

XL2005

Note1: Stresses greater than those listed under Maximum Ratings may cause permanent damage to the device. This is a stress rating only and functional operation of the device at these or any other conditions above those indicated in the operation is not implied. Exposure to absolute maximum rating conditions for extended periods may affect reliability.

XL2005 Electrical Characteristics

T_a = 25°C ;unless otherwise specified.

Symbol	Parameter	Test Condition	Min.	Typ.	Max.	Unit
<i>System parameters test circuit figure4</i>						
VFB	Feedback Voltage	V _{in} = 8V to 30V, V _{out} =5V I _{load} =0.2A	780	800	820	mV
Efficiency	η	V _{in} =12V , V _{out} =5V I _{out} =1.5A	-	90	-	%

Electrical Characteristics (DC Parameters)

V_{in} = 12V, GND=0V, V_{in} & GND parallel connect a 100uf/35V capacitor; I_{out}=500mA, T_a = 25°C ; the others floating unless otherwise specified, system parameters reference figure4.

Parameters	Symbol	Test Condition	Min.	Typ.	Max.	Unit
Input operation voltage	V _{in}		8		32	V
Shutdown Supply Current	I _{STBY}	V _{EN} =0V		60	200	uA
Quiescent Supply Current	I _q	V _{EN} =2V, V _{FB} =V _{in}		2.5	5	mA
Oscillator Frequency	F _{osc}		128	160	192	KHz
EN Pin Threshold	V _{EN}	High (Regulator ON) Low (Regulator OFF)		1.7 1.1		V
Output Power PMOS	R _{dson}	V _{FB} =0V, V _{in} =12V, I _{sw} =2A		60	80	mohm
Output Voltage Set	VFB	V _{out} =(1+R ₂ /R ₁)*VFB	0.78	0.8	0.82	V

Typical Application Circuit (Car Charger)

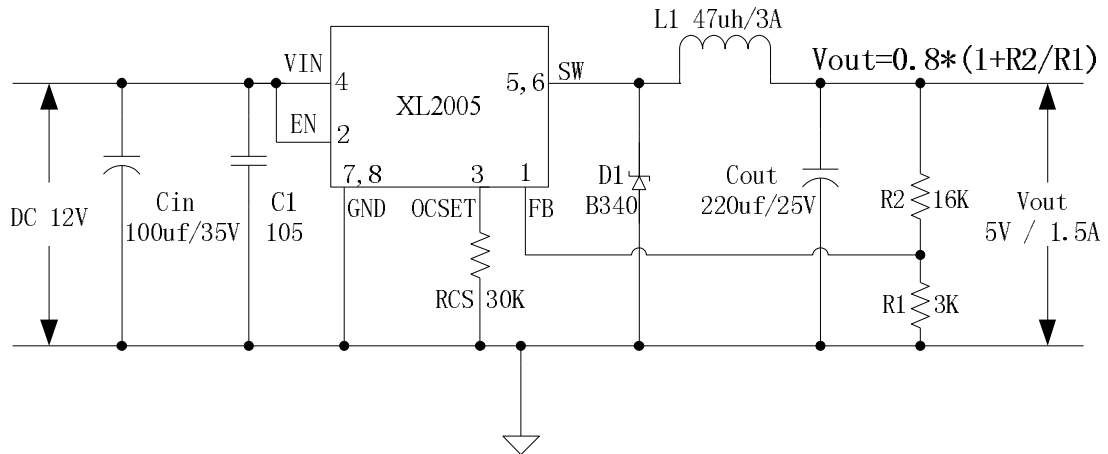

Figure4. XL2005 Typical Application Circuit (Car Charger)

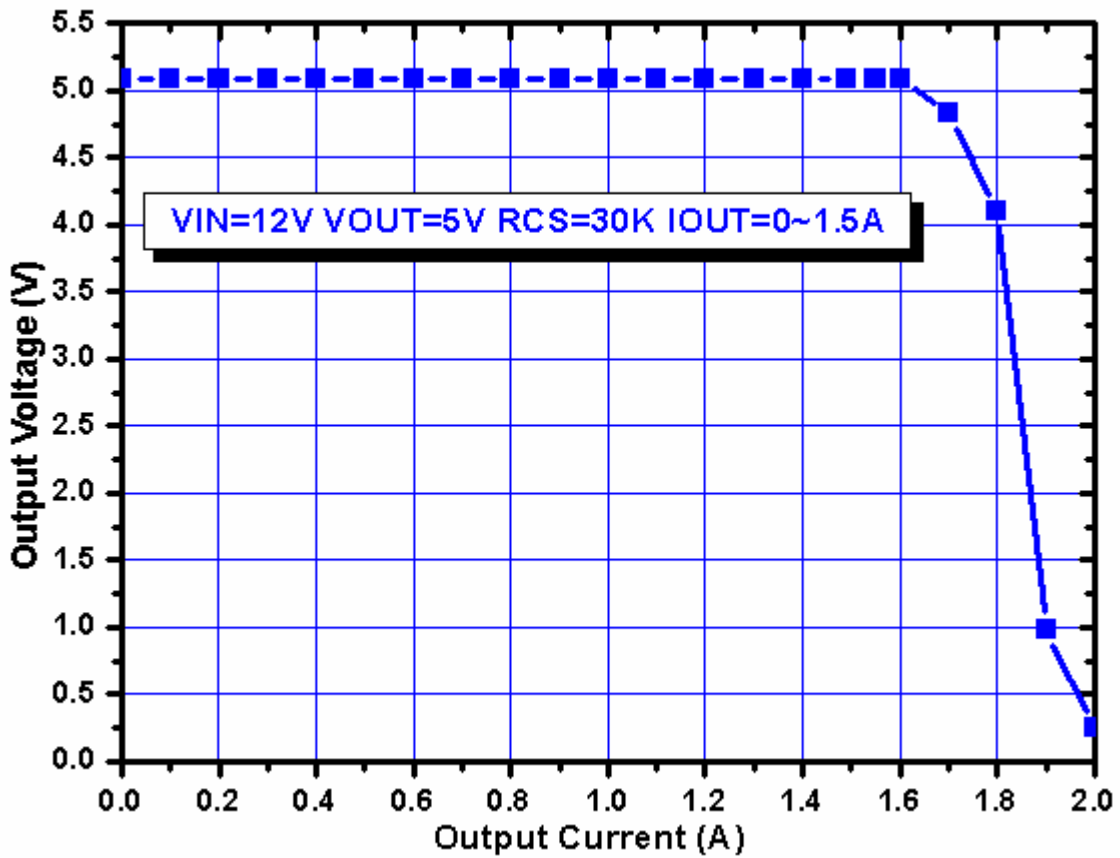

Figure5. Output Voltage VS Output Current Curve

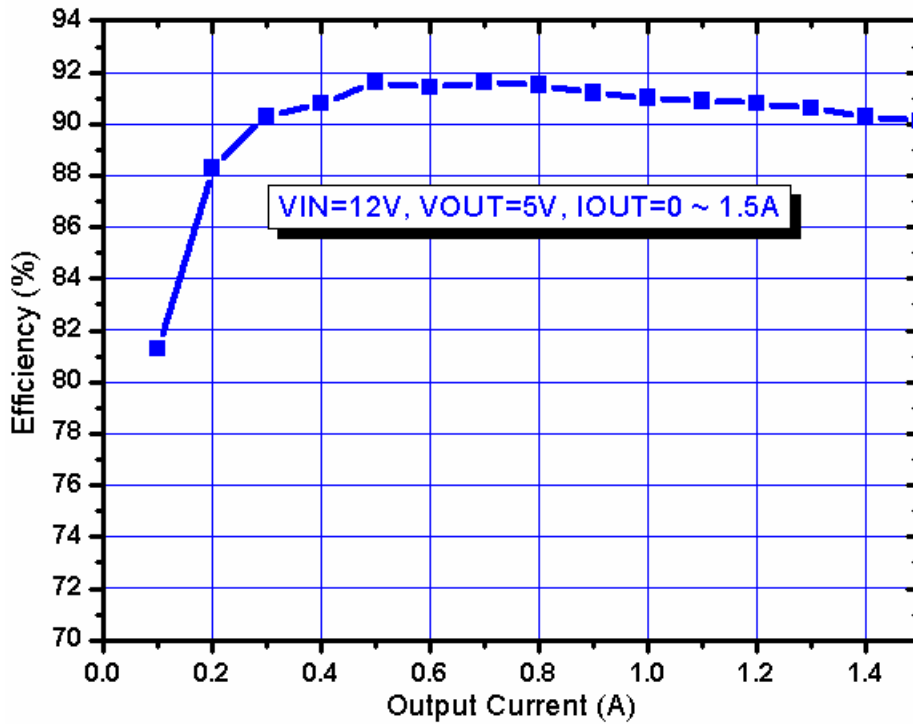

Figure6. Output Current VS Efficiency Curve

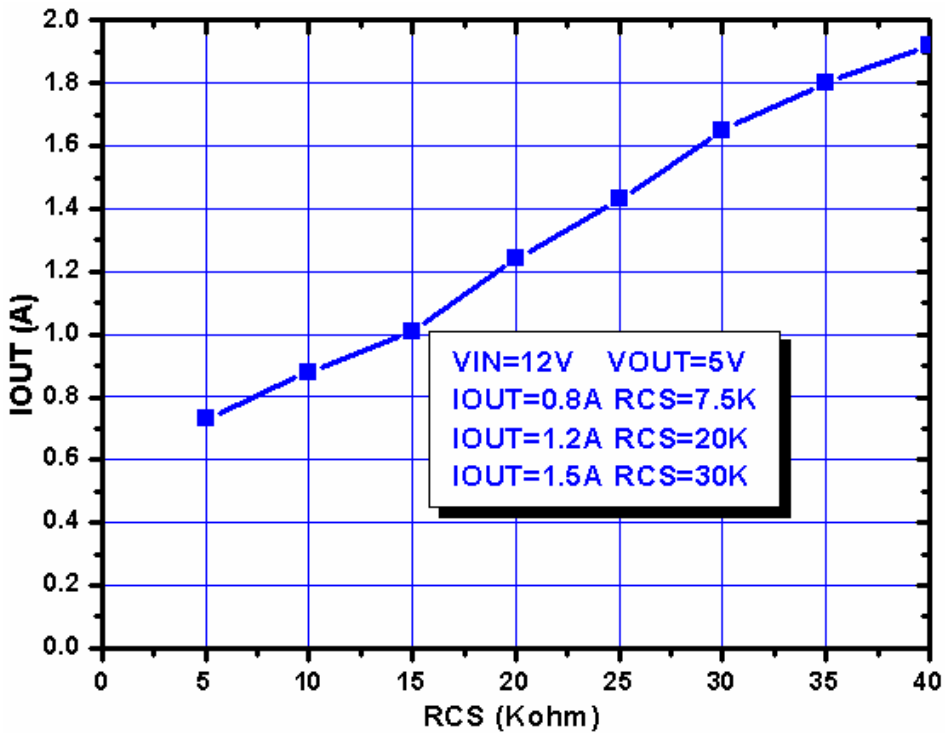

Figure7. RCS VS Output Current Select Curve

Schottky Diode Selection Table

Current	Surface Mount	Through Hole	VR (The same as system maximum input voltage)		
			20V	30V	40V
1A		√	1N5817	1N5818	1N5819
	√		SS12	SS13	SS14
3A		√	1N5820	1N5821	1N5822
		√	MBR320	MBR330	MBR340
	√		SK32	SK33	SK34
	√			30WQ03	30WQ04
		√		31DQ03	31DQ04
		√	SR302	SR303	SR304

Package Information
SOP8 Package Mechanical Dimensions

SOIC-8

Unit: mm(inch)

